

ICP OES - 3500D

Inductively Coupled Plasma Optical Emission Spectroscopy



EPCC / PRODUCTS / APPLICATION / SOFTWARE / ACCESSORIES / CONSUMABLES / SERVICES

Analytical Technologies Limited

An ISO 9001 Certified Company

www.analyticalgroup.net

Product introduction :

The ICP-OES 3500 D inductively coupled plasma emission spectrometer adopts a with newly developed vertical torch dual observation technology, which can measure elements of relatively large differences in content in a complex matrix. The patented self-excited all-solid-state RF power supply ensures that the system will have excellent adaptability to samples, and offers a low-power standby mode, which greatly reduces argon consumption. The unique large area array high-sensitivity ECCD sensor brings better performance to the product. Combined with many years of experience of Analytical in spectroscopy instrument development, the 3500D Type ICP-OES product offers the 8-hour stability index RSD of $< 1\%$, and the precision RSD of twin internal standard method of $< 0.1\%$, and thus brings you stable and reliable analysis results.

features of product :

A new generation of vertical torch dual observation technology

The ICP OES 3500D product adopts a newly developed vertical torch dual observation technology, which greatly reduces argon consumption and torch consumption, and can be used to measure elements of relatively large differences in content in a complex matrix. The vertical torch prevents high salt deposition, and the radial observation avoids matrix interference, with which better sensitivity and repeatability can be achieved. The innovative vertical observation technology with adjustable height can optimize the observation position for different elements.

Patented self-excited all-solid-state RF power supply

The product integrates the self-excited all-solid-state RF power supply with Analytical's third-generation patented technology to ensure that the equipment has better sample adaptability and stability. There won't be any flameout even if organic samples or even air is directly injected, thus eliminating the need for pre-treatment and preparation pr-

processes for organic samples such as oil products. The power range of the power supply is (500-1600) W, and its power adjustment range is better than that of most mainstream products. In the 500W low-power standby mode, the argon consumption is 5L/min, which adequately saves the cost of argon consumables for the user, and eliminates the waiting time required between the repeated turning on and off of the stable RF power supply.

The large area array ECCD sensor improves the sensitivity and spectral range of the instrument

As for the proprietary large area array ECCD sensor, its excellent low noise and deep ultraviolet response combined with anti-overflow design, provide the Analytical3500D with good detection limits. The large area array design ensures that the instrument can truly acquire the full spectrum in one take, and finish analyzing 72 elements in 10s

8-hour stability RSD < 1%

Through high-precision temperature gradient field simulation, and air duct fluid dynamics simulation, in combination with repeated practical verification, the internal structure design has been optimized, which gives the structure greater resistance to environmental temperatures. Since the stability design of many key components such as RF power supply and injection system is incorporated into the instrument, the high stability of 8 hours RSD is below 1%, which has reached the leading level internationally.



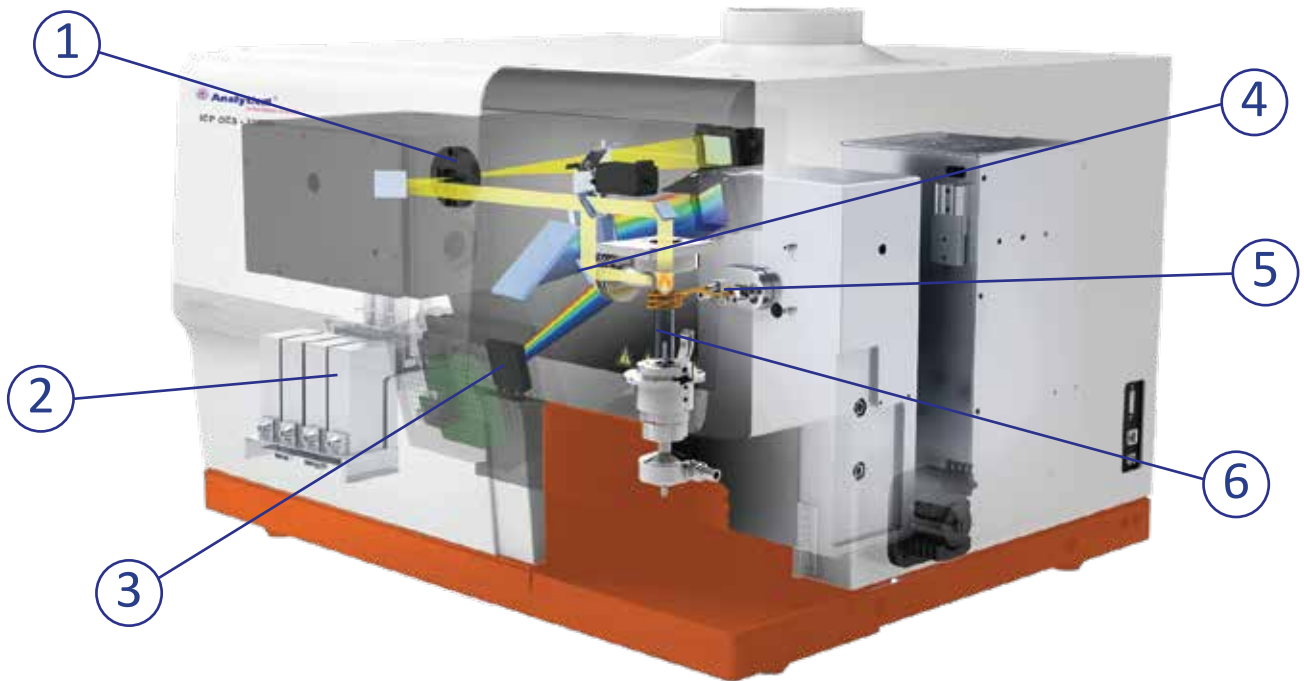

1. Stable and efficient optical system :

- All-solid-state constant temperature two-dimensional optical system.
- Full-spectrum real-time correction system, ready to be used after it is booted.
- Less refraction and reflection to ensure less loss of UV light intensity

2. Efficient multi-channel MFC :

- Atomizing gas, cooling gas, and auxiliary gas, under precise control.
- Expandable gas dilution function for high-salt samples to be analyzed directly.

3. Large area array ECCD :

- 1 square inch photosensitive area.
- Up to 72 elements can be collected in one exposure.
- Large pixel size that improves sensitivity.
- High intensity of deep ultraviolet.

4. Intelligent dynamic adjustment of gains :

- Intelligent attenuation, with which samples of concentration of 1 to 100 times can be handled easily.
- With the unique dynamic integration technology, samples with various concentrations can be handled easily

5. Self-excited all-solid-state RF source :

- 500 W to 1600 W power that is continuously adjustable
- Incorporated with iStandby low power standby mode to reduce argon consumption
- Better power stability

6. Bidirectional observation with vertical torch :

- With both the sensitivity and the high salt matrix resistance taken into balanced consideration, the observation position can be adjusted according to the distribution of elements on the plasma, without additional treatment of tail flame.

All-digital self-excited all-solid-state RF power supply with iStandby mode

Fully digital power supply control: The RF power supply based on dual power supply technology is continuously adjustable over the wide power range of 500W to 1600W, with better sample adaptability.

- Self-excited RF power supply : The matching is quick, thus offering adaption to complex sample analysis and switching; there are no moving parts, which makes the instrument more reliable.
- iStandby mode : The mode enables the ultra-low power standby function, and reduces argon consumption by more than 50%.
- The water-cooled design enables rapid heat dissipation, and the power stability is within 0.1%, thus guaranteeing the reliability.

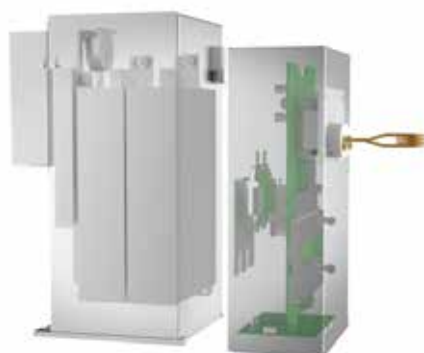

All-digital self-excited all-solid-state
radio frequency power supply

Stable and efficient two-dimensional optical system with echelle grating

- Efficient two-dimensional spectroscopic system, with less reflection times and less light energy loss.
- Heat-balanced control light chamber at constant temperature of 36 degrees, as cornerstone of stable instrument.
- The distributed purge is designed based on fluid mechanics simulation, and enables the optical system to quickly establish a high-purity argon atmosphere, and thus realizes the ultraviolet analysis, and save both the time and argon.
- The thermal isolation design of the host and the optical system balance the heat exchange, makes the optical system better resistant to the influence of changes in the external environment.
- Applications on vehicles are supported in a stable and reliable way.

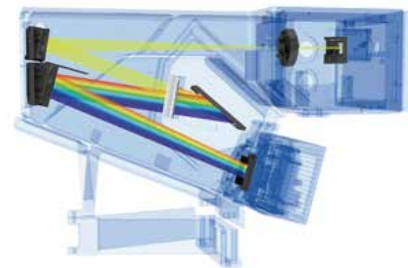
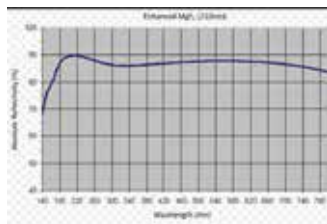
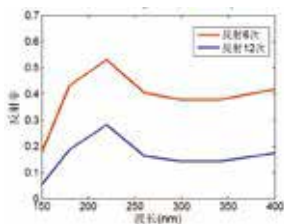

Comparison chart of efficiency of lens reflection efficiency chart of multiple reflections

Proprietary high-performance large area array ECCD

- square inch large area array CCD detector: The pixel size is large, which brings about high-sensitivity response, and the overall area is large, with which a wider spectral range can be obtained while the high resolution is maintained.
- 1024*1024 pixels, one-time exposure : Realization of detection of 72 elements in range of 160 nm to 900 nm, and obtainment of results in 10 s.
- Obvious hierarchy of deep ultraviolet zone has, and high sensitivity
- Back-vented anti-overflow design, with no need for worries about the influence of spectral line saturation on adjacent spectral lines
- TEC refrigeration packaged inside the sensor that directly acts on the pixel Integrated, efficient, and highly reliable, and more conducive to eliminating influence of thermal noise..



Back-vented anti-overflow design :

Even in the 800 nm to 900 nm waveband where the argon line overflow is strong, the spectrum of effective elements can still be clearly distinguished.

Good UV response

The intensity of C and Al spectral lines around 160 nm is good. The ultraviolet waveband hierarchy is clearly visible. .

New generation of dual observation technology with vertical torch

The vertical torch reduces argon consumption, and prevents high salt deposition. The vertical torch prolongs the service life of the torch, and reduces the consumption of torch consumables.

Axial observation: High sensitivity.

Radial observation : The interference by matrix is prevented. The position of plasma light can be adjusted. And the element acquisition can be optimized according to different positions of the plasma.

Bidirectional observation: Having the advantages of both (axial and radial), and outperforming both.



The patented real-time drift correction technology corrects the spectral positions

Only C, N, and Ar spectral lines are used for start-up and ignition, and the spectrum correction is automatically completed without specific sample injection.

The patented full-spectrum real-time correction (FSC) technology uses the characteristic line of the non-interfering neon to correct the subtle deviations of the spectrum in real time, so that better spectral integration can be achieved to ensure good long-term stability.



Intelligent dynamic gain adjustment "triple hit", easy control over any concentration gradient

Intelligent attenuation, with which samples of concentration of 1 to 100 times can be handled easily

The attenuation multiple is automatically increased according to the high and low concentration of elements to complete the analysis of a sample with a steep gradient of the elements of high and low concentrations at one time without repeated dilution, which reduces the difficulty of sample pre-treatment.

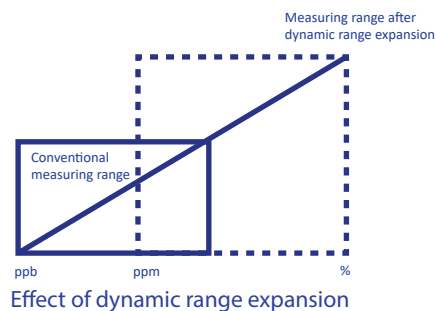

Smart integration

Patented intelligent integration design: Signals and background are acquired at synchronously; the exposure time depends on the light intensity of the spectrum; the best exposure time of the spectrum is calculated automatically; the light intensity is normalization calculated; the working curve is combination calculated; the integration time control is accurate to the microsecond; the dynamic range is widened; and the repeated dilution of the sample is avoided

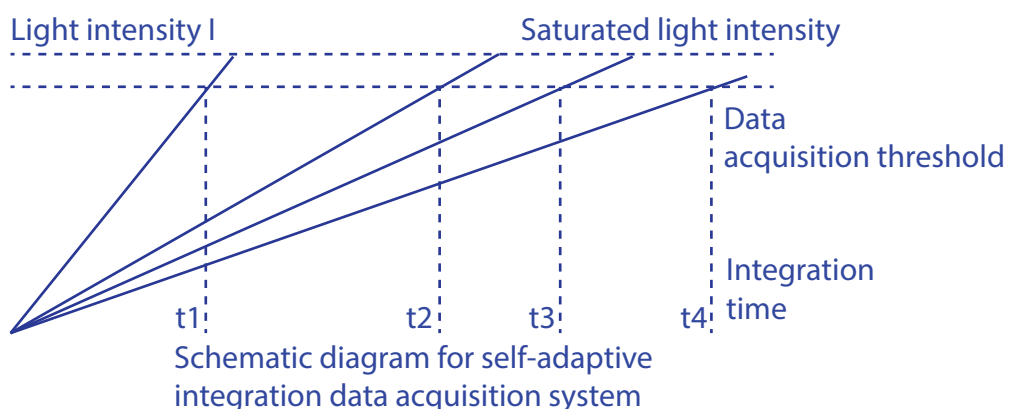

Argon online dilution

Effective dilution of high salt samples of more than 10% is achieved by adding a channel of argon gas for dilution which is controlled by MFC before the aerosol in the atomization chamber enters the torch, and the difficulty of sample pre-treatment is thus reduced.



Schematic diagram for argon dilution input

Stable injection system

- Multi-channel digital mass flow controller, providing precise control over each channel of argon, with the control accuracy at 0.01 L/min, to ensure the stability of the data measured.
- The high-precision 12-rotor 4-channel peristaltic pump ensures stable sample injection, and can add internal standard solution and standard addition solution according to the needs, which is conducive to complex sample analysis.
- Fully split-body torch, the installation of which is self-collimating; for different applications, only the center tube needs to be replaced, which greatly reduces costs.



High-precision 12-rotor 4-channel peristaltic pump



Multi-channel MFC

Supporting expansion with a variety of accessories



Automatic injector



Hydride generator



Organic injection system

Organic injection system

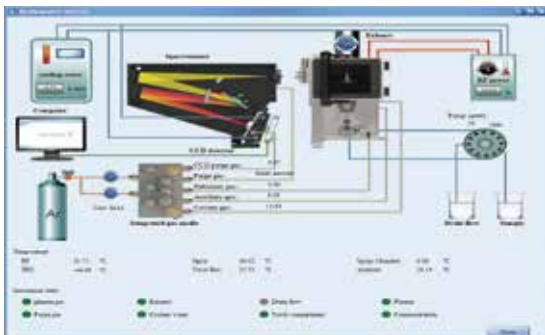

Windows-style operation interface

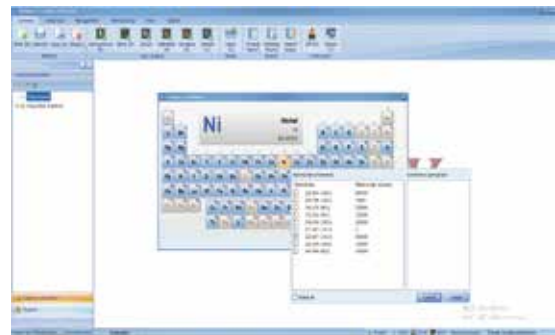

Method backup and import



Full spectrum and sub-array controls

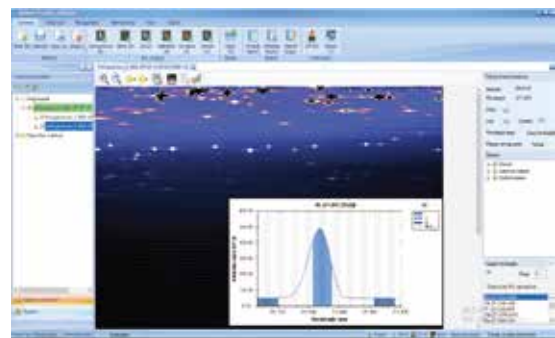

Technical Specification :

1. Application scope

The 3500D full-spectrum direct-reading ICP-OES has the excellent anti-interference, analysis and detection performance, and is used to fulfill the high-end analysis demands in research and development as well as detection. And it can be used to carry out qualitative, semi-quantitative and precisely quantitative analysis easily, the ideal instrument for the simultaneous analysis of major, minor and trace inorganic elements

2. Work environment

voltage: 220V AC \pm 10%

Room temperature: ambient temperature (10-30)

Relative humidity: (20-80)%RH

3. Technical specifications

3.1. RF plasma source:

3.1.1: The RF power with the design of dual power supplies under full digital control has a wider power range of 500 W - 1,600 W, the adjustable power, and the stronger sample adaptability.

3.1.2: Self-excited RF generator: the self-excited power supply can be used to analyze 100% methylbenzene samples directly thanks to its high matching speed and strong power load capacity. It also has the functions of automatic tuning and water cooling, and thus is adaptable to the power switching for complex sample analysis. As it has no moving part, it is resistant to either vibration or interference, which makes it more reliable;

3.1.3: iStandby mode: in this mode, the ultra-low power of 500 W for standing by is provided, and the argon consumption is reduced by over 50%; the argon consumption during the standby period is smaller than or equal to 5 L/min;

3.1.4: Observation method of plasma: four observation modes are configurable, i. e. axial, radial, bi-directional and simultaneous bi-directional observation modes. The adoption of vertical rectangular tubes can prevent high-salinity deposition, extend its

service life, and reduce the use of its consumables. In axial observation, the metal cooled cone is adopted to remove tail flame, and obtain high sensibility; no configuration of any air compressor is required, saving both external fittings and consumption. In radial observation, the location of plasma observation is adjustable for the analysis elements of different elements, providing the stronger anti-interference capacity;

3.1.5: Intelligent attenuation: there are the functions of axial attenuation and radial attenuation, and the attenuation of the samples with the concentration within 100 times is realizable. This means the analysis of the element that has a high content in the sample can be completed at the first time, requiring no repeated dilution. In this way, the preprocessing of the sample will be less difficult, and the analysis can be simplified;

3.1.6: Radio Frequency (RF): 27.12 MHz; coupling efficiency: >80%;

3.1.7: RF power stability: $\leq 0.1\%$; RF stability: $\leq 0.01\%$

3.2. Optical system:

3.2.1: The thermostatic 3D optical system has a few reflections and a low optical energy loss. All optical elements are sealed in the thermal balancing optical chamber, and the host and optical chamber are isolated thermally, which can resist the external ambient temperature changes well. Optical chamber: precise; kept at the constant temperature of $36\text{ }^{\circ}\text{C} \pm 0.1\text{ }^{\circ}\text{C}$; argon removing;

3.2.2: Stable, efficient fully-fixed echelle optical-splitting system: with no moving parts but high vibration resistance, stability and reliability;

3.2.3: Wavelength range: 160 nm - 900 nm, with full wavelengths covered;

3.2.4: Monochromator: focal length=380 mm; with the total reflection imaging optical path and quartz prism 2D dispersive system;

3.2.5: Echelle grating: 87 L/mm, 63.5° blazing; the larger the number of ruled grating lines is, the higher the resolution will be;

3.2.6: Wavelength correction: For each time of ignition, only spectral lines of C, N and Ar are used for the automatic correction of the spectral position to ensure the correctness of analysis wavelengths, and no wavelength correction solution is required;

3.2.7: Patented full-spectrum real-time calibration technique (FSC): the interference-

free Ne characteristic spectral line is utilized to fulfill the real-time calibration of the fine spectrum offset, realize the optimal spectral integral, ensure long-term stability, and eliminate the effect of the spectral drift on measurement well.

3.2.8: Purging optical chamber: for the determination of the wavelengths shorter than 189 nm, argon is selected to purge the optical path, and no vacuum pump is required to prevent the vacuum return oil that will contaminate the optical chamber;

3.2.9: Stray light: ≤ 2.0 mg/L (10,000 mg/L Ca solution is determined at the location of As 188.980 nm)

3.2.10: Optical resolution (FWHM): ≤ 7 pm @ 200 nm;

3.3. Detector: special large-area array ECCD detector with pixel-level refrigeration

3.3.1: Detection unit: large-area array CCD detector with the 1,024*1,024 pixel size, in a single exposure;

3.3.2: Imaging size: 25.4 mm \times 25.4 mm large-area array imaging and photosensitive units; the large picture element of 24 μ m \times 24 μ m is adopted to fulfill high-sensitivity response; as the overall breadth is large, both the high resolution and a wider spectral range can be obtained;

3.3.3 : Pixel-level refrigeration: the TEC refrigeration part that is encapsulated in the sensor acts on the pixel element directly, and the cryogenic temperature is higher than -10°C which can effectively prevent the CCD surface condensation while require no gas purging protection;

3.3.4: Anti-saturation overflow: the back relief anti-overflow protection is designed for each pixel to eradicate thoroughly the problem of spectrum saturation overflow, and eliminate the concern about the effect of spectrum saturation on the adjacent spectrum;

3.3.5: Design of intelligent integrates : for the synchronous acquisition of the signal background , the time of exposure is dependent on the spectral luminous intensity; the best time of exposure for the spectrum line is calculated automatically, and both the high-intensity signals and weak signals based on the best signal-noise ratio are obtained; the dynamic range is widened, which enables the simultaneous detection of high-content elements and low-content elements and prevents repeated sample dilution;

3.3.6: There is no light-conversion chemical coating on the detector surface, and there will be no detector damage or change caused by coating aging

3.4. Sample introduction system:

3.4.1: Sampling system: the quartz concentric nebulizer, quartz swirling flow atomizing chamber and detachable rectangular tubes are the standard accessories;

3.4.2 : Argon is optional for on-line dilution. The high-precision MFC controls argon to dilute efficiently the high-salinity samples with the saltiness over 10%, and samples are introduced directly.

3.4.4: The sampling system resistant to high salinity or HF, the organic sampling system and hydride generators are optional;

3.4.5: Peristaltic pump: 12-roller 4-channel peristaltic pumps are adopted, and the pump speed is adjustable from 0 rpm to 125 rpm automatically and continuously. When stable sampling is ensured, the simultaneous operation of sampling tubes, internal standard tubes, waste liquid tubes and accessory reagent tubes (the hydride generator) can be supported, which is conducive to the analysis of complex samples;

3.4.6: Control of the gas channel: the precise mass-flow controller is adopted to control the flow of multiple-channel gases, and at most 5 channels can be controlled, including the atomization gas, auxiliary gas, cooling gas and additional expandable gases (O₂ and Ar), with the accuracy of 0.01 L/min

3.5. Software performance:

3.5.1: Thanks to the graphical operation interface, the software operation is visual and easy. The interface provides the functions of qualitative, semi-quantitative and quantitative analyses;

3.5.2: The method library management software based on classification and versions is conducive to the management, maintenance and preservation of methods; some standard methods that are built in the software can facilitate analysis efficiency;

3.5.3: It has the function of full-spectrum data acquisition, and can record the spectrum lines of all elements. The data can be stored safely, and the functions of both analysis data storage and retrieval are supported for reanalysis in the future;

- 3.5.4: There is a spectral line library with over 50,000 spectral lines, and at least 30 pixels for each spectral line can be selected for measurement;
- 3.5.5: It has the function of full-spectrum acquisition, and a complete full spectrum can be obtained from the software to know about the sample spectrum and spectrum interference status;
- 3.5.6: It has multiple interference-correction methods and the function of real-time background subtraction, such as the standard comparison method, internal standard method, interfering element correction coefficient method (IEC) and standard addition/curve methods, which enrich users' multiple means of analysis and study;
- 3.5.7: It has the function of instrument calibration, and supports the functions including rectangular tube collimation and light source optimization, which are conducive to users' routine maintenance. It also provides the visualized monitoring of instrument operation status;
- 3.5.8: It provides the login password protection, multi-level operation permission setting, network security management, and permanent storage of historic records;
- 3.5.9: It has the visualized observation module of rectangular tube flames;
- 3.5.10: There is English software;
- 3.5.11: It has the function of network-based remote service, and has a built-in remote service assistant for remote diagnosis; the 4G Network Data Connection Technology Service Department fulfills the remote diagnosis and maintenance of instruments;
- 3.5.12: The software design is in complete compliance with the 21 CFR Part 11-regulation of electronic signature; the software provides the three-level administrative authority and the function of audit trailing, conforming to the regulation requirements, such as 3Q certification;
- 3.5.13: It can integrate the software operations of the automatic analysis instrument platform and on-line analysis instrument platform.

3.6. Analysis performance:

- 3.6.1: Analysis speed: about 200 spectral lines per minute;
- 3.6.2: Sample consumption: only 2 ml;
- 3.6.3: The determined linear dynamic range of spectral lines: $\geq 10^5$ (determined by using

Mn 257.6 nm; the relevant coefficient ≥ 0.999)

3.6.4: Precision: determine 1 ppm or 10 ppm multi-element mixed standard solutions; the RSD from the repeated 10 times of determination: $\leq 0.5\%$;

3.6.5: Stability: determine 1 ppm or 10 ppm multi-element mixed standard solution; the RSD, for the long-term stability over an 8-hour period: $\leq 1\%$;

3.6.6: Detection limit: (unit: $\mu\text{g/L}$, the element conforms to the specifications of JJG 768-2005)

Zn213.856	Ni231.604	Mn257.610	Cr267.716	Cu324.754	Ba455.403
0.5	1	0.5	1	1	0.1

3.6.7: It can implement qualitative, semi-quantitative and quantitative analysis of any spectral line for the analysis element; it also supports the methods including the internal standard method, standard addition method and interfering element correction;

3.6.8: Preheating time: the duration from the standby period to the time when the plasma is ignited is shorter than 5 minutes.

3.7. Instrument interface (including coupling analysis software):

3.7.1: It can fulfill the coupling of the automatic digestion sample processing workstation (in the digestion system, the graphite-digestion electro-thermal mode is adopted to realize the automatic digestion, isochoric and sampling operations, and the simultaneous processing of the samples at over 48 sites is supported)

3.7.2 : It is equipped with the analysis system interface for direct organic sample introduction (it provides the function of sample refrigeration, with the temperature below 15°C)

3.7.3 : It is equipped with the on-line digestion module interface (supporting the functions of on-line automatic electric heat digestion and concentration control as well as the automatic cleaning of sampling pipelines);

3.7.4 It is equipped with the on-line analysis system interface for hydride generation (supporting the functions of the automatic addition and concentration control of reactive liquid as well as the automatic cleaning of sampling pipelines);

3.7.5 : It can be connected to the ion exchange workstation for valence analysis or the analysis of low-concentration enrichment high-matrix removal;

3.7.6 : It can be connected to the automatic sample injector for analysis(supporting the configurability of over 240 sample sites);

4. Accessory system:

4.1 Computer system

4GB memory, 500G hard disc; with the DVD, keyboard and mouse

4.2 Cooling circulating water system

The refrigeration capacity of 1,490 W; temperature scope of 5°C - 35 °C.

4.3 Laser printer

Black and white laser printer

4.4 Single-phase AC voltage regulator

10KVA, accuracy of 1%, input voltage of 160 V - 280 V, output voltage of 220 V.

5. After-sales service

Project building is a complex, long-term technical service. In order to fulfill the system service earnestly, the following principles are prepared as the main principles of instruction:

- Principle of response timeliness

The Technical Service Department and Customer Service Center of the Analytical will undertake the quick response of the construction of this project, and provide technical consultation service in time.

- Principle of normative service

Our implementation engineers, technical supporting engineers and maintenance engineers do not only have professional technical skills, but also have been certified by the training about the company's customer service specifications. They provide customer service in strict accordance with our company's customer service specifications

- Principle of high efficiency in solving problems

The principle of the high efficiency in solving problems refers to the quick positioning and problem solving through the professional skills of the site supporting engineers.

- Process of customer service response

To ensure the timely response to and standard service for customers problems, the company has established a scientific, reasonable customer service response system. The Customer Service Center of the Analytical Technologies Limited will provide technical consultation services for customers.

- Periodic preventive system maintenance

The status report is required for periodic inspection. In the report, there shall be the detailed error recording of each part of hardware, and measures can be adopted as soon as possible accordingly to eliminate hidden faults. The engineers of our company's Technical Center periodically implement remote login by the Internet to fulfill 24-hour automatic reporting and tracking against problems. Then, these engineers can provide timely maintenance and repair based on the relevant results. Periodic equipment testing and inspection are implemented to find out hidden faults, and to eliminate them as soon as possible.

- Rapid site service

If there is any system failure diagnosed in the customer's system that cannot be solved by means of telephone/email, remote dial-in analysis, etc., our site engineers will immediately take along the corresponding system tools and software, and head for the site for emergent maintenance. We promise that we will respond to customers within 24 hours after the system failure, and will arrive at the customer's site within 3 working days in case of any site maintenance.

- Periodic visit and communication

During the operation of the customer's system, we will adopt the method of designating special personnel to implement visits and communication regularly or irregularly to investigate the project implementation and maintenance, listen to customers' opinions, solve customers' problems at site, as well as test and optimize systems at site. In this way, we can find out system problems or hidden faults, eliminate hidden faults in advance, ensure safe, stable system operation, and fulfill the quality assessment of the system.

The above customer service response methods are not isolated or unrelated to each other. However, supported by the organizational structure of the Customer Service Center of the Analytical Technologies, multiple flexible service modes permeate into, and are combined closely with, each other, forming a complete, unified fault response system for customers' service. This system has been experienced practically in many large-scale working projects, and has been considered as the efficient, feasible and optimal fault response method

HPLC Servicing, Validation, Trainings and Preventive Maintenance :

HPLC Servicing :HPLC Servicing : We have team of service engineers who can attend to any make of HPLC promptly @the most affordable cost.

Trainings :We also take up preventive Maintenance to reduce downtime of HPLC's Trainings.

AMC's/CMC :AMC's/CMC :We offer user training both in-House and at customer sites on HPLC principles, operations, trouble-shooting.

Validations :Validations :We have protocols for carrying out periodic Validations as per GLP/GMP/USFDA norms.

Instruments :Instruments :We offer instruments/Renting Services Modules like pumps,detector etc. on Rent.



About Analytical Technologies

Analytical Technologies is synonymous for offering technologies for doing analysis and is the Fastest Growing Global Brand having presence in at least 96 countries across the global. Analytical Technologies Limited is an ISO:9001 Certified Company engaged in Designing, Manufacturing, Marketing & providing Services for the Analytical, Chromatography, Spectroscopy, Bio Technology, Bio Medical, Clinical Diagnostics, Material Science & General Laboratory Instrumentation. Analytical Technologies, India has across the Country operations with at least 4 Regional Offices, 6 Branch Offices & Service Centers. Distributors & Channel partners worldwide.

Our Products & Technologies



UV/VIS
Spectro 2080+
Double Beam



Infra FTIR



Optima Gas
Chromatograph
3007

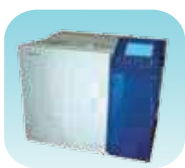

Optima Gas
Chromatograph
2979 Plus



Flash
Chromatograph



Atomic Absorption
Spectrophotometer



Liquid Partical
Counter



Optical Emission
Spectrophotometer



DSC/TGA



Semi Auto Bio
Chemistry Analyzer



HEMA 2062
Hematology
Analyzer



Micro Plate
Reader/Washer



URINOVA 2800
Urine Analyzer



Total Organic
Carbon 3800



Fully Automated
CLIA



NOVA-2100
Chemistry Analyzer



PCR/Gradient PCR/
RTPCR



TOC
Analyzer



Laser Particle
Size Analyzer



Ion Chromatograph



Water purification
system

Regulatory compliances



Corporate Social Responsibility

Analytical Foundation is a nonprofit organization (NGO) found for the purpose of:



Analytical
Foundation

1. Research & Innovation Scientist's awards/QC Professional Award : Quality life is possible by innovation only and the innovation is possible by research only, hence ANALYTICAL FOUNDATION is committed to identify such personalities for their contributions across various field of Science and Technology and awarding them yearly. To participate for award, send us your details of research / testing / publication at Info@analyticalfoundation.org

2. Improving quality of life by offering YOGA Training courses, Work shops/Seminars etc.

3. ANALYTICAL FOUNDATION aims to DETOXYFY human minds,souls and body by means of yoga, Meditation, Ayurveda, Health Care, Awards, Media, Events, Camps etc.

Reach us @



HPLC Solutions MultipleLabs Analytical Bio-Med Analytical Distributors Analytical Foundation (Trust)

Corporate & Regd. Office:
Analytical House, # E67 & E68,
Ravi Park, Vasna Road, Baroda,
Gujarat 390 015. INDIA

T: +91 265 2253620
+91 265 2252839
+91 265 2252370
F: +91 265 2254395

E: info@hplctechnologies.com
info@multiplelabs.com
info@analyticalgroup.net
info@analyticalbiomed.com

W. www.analyticalgroup.net
www.hplctechnologies.com
www.multiplelabs.com
www.ais-india.com

Sales & Support Offices:
across the country :
Distributors & Channel
partners World Wide

Note : Company reserves rights to add/delete/modify the contents / technical specifications of the catalogue without prior notice.